

LEAF INFORMATION

WIDTH	THICKNESS	POUND CAPACITY	MAX DEFLECTION @ 4500#
1.75"	.360"	2750#	2.125"

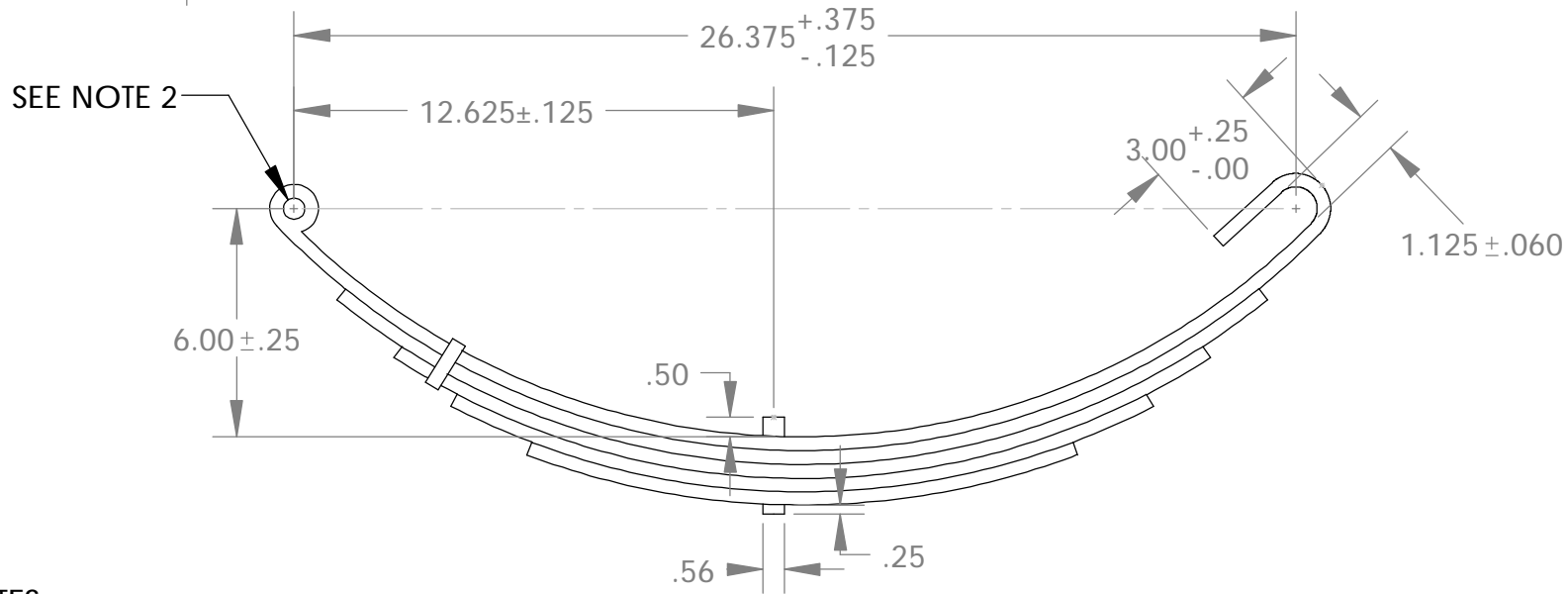
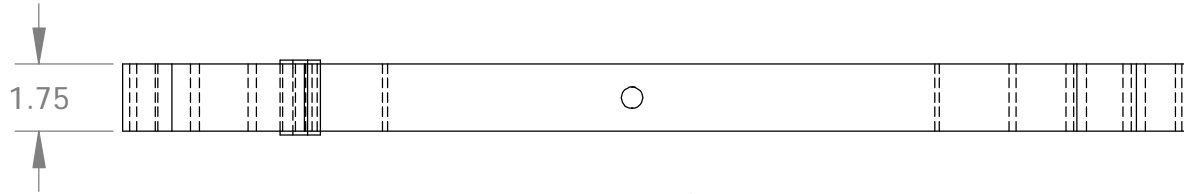
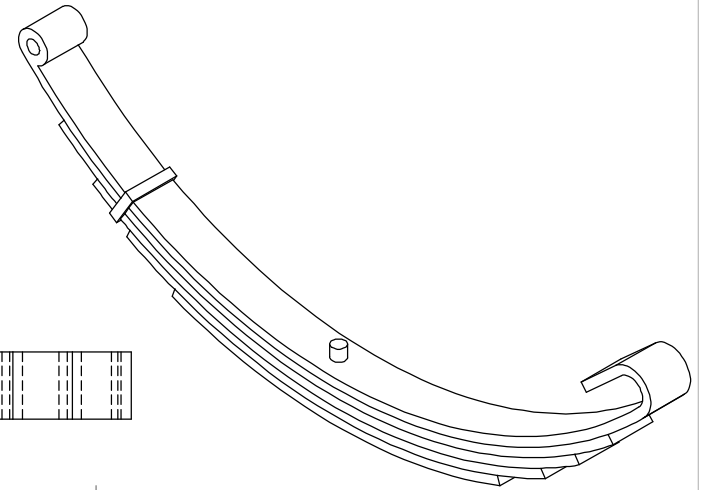

- NOTES:
 1.) PICTORIAL IS GENERIC, STANDARD CONST. APPLIES
 2.) MANUFACTURER NOTES:
 * MATERIAL: SAE 5160 STEEL
 * CLIP 1.00" FROM END OF LEAF #3.
 * USE .688" X .563" X 1.75" NYLON BUSHING.
 * USE .375" X 2.25" C'BOLT & NUT
 3.) FINISH: ALUMINIZED COATING.

ALL DIMENSIONS ARE IN INCHES UNLESS OTHERWISE STATED TOLERANCES EXCEPT AS NOTED

DECIMALS:

.X	±0.100
.XX	±0.060
.XXX	±0.030
.XXXX	±0.010

ANGLES:

±1°
 ALL FORMED ANGLES EQUAL 90° UNLESS NOTED OTHERWISE

() INDICATES REFERENCE

THE INFORMATION IN THIS DRAWING IS THE SOLE PROPERTY OF KARAVAN TRAILERS, INC. ANY REPRODUCTION IN PART OR WHOLE WITHOUT THE WRITTEN PERMISSION OF KARAVAN TRAILERS, INC. IS PROHIBITED

APPROVED BY:

DRAWN BY: C-RICHTER

DATE: 07-15-02

SHEET: 1 OF 1

SCALE: N/A

KARAVAN

TITLE: SPRING, HOOK, 5-LEAF

MAT'L: PURCHASED

FINISH: N/A

DWG. #: 219-00019

DWG. REV.	ECR/NDR NUMBER	REVISED BY	DATE	DESCRIPTION
A/2	15726	KMH	01-06-14	26.375+.375/-.125 WAS 26.375 ± .125 & 6.00 ± .25 WAS 6.00 ± .125
A/1	13361	TMM	12-29-05	ADD NOTE 3. ADD TOP VIEW. TITLE WAS 5-LEAF HOOK SPRING.